



Thermaltake Technology Co.,Ltd

Power Product Function Test Report

Title	Product Operation Test and Verify
Product Name	Toughpower
Document Number	RDW051506-3
Product Model Name	W0133
Date	2006/10/18

Contents

A. Product SpecificatioContent.....	2
B. Complete Function Check Report Function Check Report.....	3
C. Test Photo of reference.....	16

Approved by:

Audited by:

Checked by:

Test by:

A. Product Specification Content

Product Source	Model Name	W0133							
	Version	N/A							
Product Struct	Appearance	Standard ATX Type							
	Output Connect Type	Normal							
	PFC Choke	Active Type							
Input Specification	Input Voltage	100V~240V							
	Input Current	16A							
	Input Frequency	50HZ~60HZ							
Output Specification	<p>1. The Continuous total output power 1200w max (1.) The combined power of +5v and +3.3v is 250w max (2.) The combined power of +12v1 and +12v3 is 600w max and +12v2 and +12v4 is 600w max</p>								
	Voltage	+5V	+3.3V	+12V1	+12V2	+12V3	+12V4	-12V	+5Vsb
	Max Load	30A	30A	20A	20A	36A	36A	0.8A	3A
	Min Load	2A	0.5A	1A	1A	1A	1A	0A	0A

B. Complete Function Check Report Function Check Report

Test Sample Model Name	W0133
Test Date	2006,11,6
Test Temperature	Ambient
Test Equipment	1. Chroma 6314 DC Electronic Load Main Frame 2. Chroma 61604 Program Mable AC Source 3. Tektronix TDS3014B Digital Phosphor Oscilloscope t Test Fixture
Power Supply Function Test Items	A. Input Test 1. Power Efficiency B. Output Test 1. Line Regulation 2. Load Regulation 3. Output Ripple & Noise C. Power Cycle Test 1. Continuous PS ON/OFF Test
Other Test Item	1. Compatibility Experiment Test

(Power Supply Function Test Items)

A. Input Test

1. POWER EFFICIENCY

1.1 Test Condition & Check

1. Test Condition:

Test the power supply with nominal line voltage and maximum load

2. Check:

Power Supply shall be a minimum percentage efficient under specified loading condition shown as below table

Output Load	Output Load Condition (A)							
	+5V	+3.3V	+12V1	+12V2	+12V3	+12V4	-12V	+5Vsb
Full Load	25	23.48	16	16	25	25	0.5	1.5

1.1 Test Result

Vin	AC 115V/60HZ	AC 230V/50HZ
Current (A)	12.94	6.47
Power (W)	1487.7	1436
Spec	N/A	

Vout Vin	Measure Voltage Value								EFF(%)	Factor	Spec
	+5V(V)	+3.3V(V)	+12V1(V)	+12V2(V)	+12V3(V)	+12V4(V)	-12V(V)	+5Vsb(V)			
115V/60HZ	4.89	3.24	12.02	11.82	11.98	11.89	-12.51	5.03	80	0.998	N/A
230V/50HZ	4.91	3.24	12.02	11.83	12	11.9	-12.51	4.99	82.98	0.954	

B. Output Test

1. LINE REGULATION

1.1 Test Condition & Check

Purpose: Measure the stability of the output voltage when the input voltage is variable

Environmental Condition: Temperature 25C relative Humidity 65%

Test Condition: 1.The input voltage frequency must be under any condition

in the range of the product specification

2.The output load is full load on all outputs at under the product specification

3.Test can be performed only after the SPS is on for about 10 minutes

Output Load	Output Load Condition (A)							
	+5V	+3.3V	+12V1	+12V2	+12V3	+12V4	-12V	+5Vsb
Full Load	25	23.48	16	16	25	25	0.5	1.5

Result Limit: The output voltage can not exceed the allowed difference

1.2 Test Result

Vin \ Vout	+5V (V)	+3.3V (V)	+12V1 (V)	+12V2 (V)	+12V3 (V)	+12V4 (V)	-12V (V)	+5Vsb (V)
100V/60HZ	4.9	3.24	12.03	11.83	12.	11.9	-12.51	4.99
115V/60HZ	4.89	3.24	12.02	11.82	11.98	11.89	-12.51	5.03
132V/60HZ	4.91	3.24	12.03	11.84	11.99	11.9	-12.51	4.99
180V/50HZ	4.91	3.26	12.04	11.84	11.99	11.91	-12.5	4.99
230V/50HZ	4.91	3.24	12.02	11.83	12	11.9	-12.51	4.99
240V/50HZ	4.91	3.24	12.04	11.83	12	11.9	-12.51	4.99
Reference Spec	+5/-5%	+5/-5%	+5/-5%	+5/-5%	+5/-5%	+5/-5%	+10/-10%	+5/-5%

2. LOAD REGULATION

2.1 Test Condition & Check

Purpose: Measure the stability of the output voltage when the load is variable

Environmental Condition: Temperature 25C relative Humidity 65%

Test Condition:

1.The input voltage frequency must be under any condition in the range of the product specification

2.Output Load Maximum , Middle , Minimum load by the product specification

Result Limit: The output voltage can not exceed the allowed difference

Output Load	Output Load Condition (A)							
	+5V	+3.3V	+12V1	+12V2	+12V3	+12V4	-12V	+5Vsb
Full Load	25	23.48	16	16	25	25	0.5	1.5
Half Load	25	25	10	10	18	18	0	0
Min Load	0.5	0.3	1	1	1	1	0	0

2.2 Test Result

Vin	Vout	+5V	+3.3V	+12V1	+12V2	+12V3	+12V4	-12V	+5Vsb
	Load	(V)	(V)	(V)	(V)	(V)	(V)	(V)	(V)
100V/60HZ	Full Load	4.9	3.24	12.03	11.83	12.	11.9	-12.51	4.99
	Half Load	4.94	3.26	12.04	11.91	12.02	11.94	-12.39	5.02
	Min Load	5.04	3.34	12.13	12.06	12.14	12.07	-12.33	5.14
115V/60HZ	Full Load	4.89	3.24	12.02	11.82	11.98	11.89	-12.51	5.03
	Half Load	4.92	3.26	12.06	11.91	12.02	11.94	-12.4	5.02
	Min Load	5.04	3.34	12.14	12.06	12.14	12.07	-12.33	5.14
132V/60HZ	Full Load	4.91	3.24	12.03	11.84	11.99	11.9	-12.51	4.99
	Half Load	4.94	3.26	12.05	11.91	12.02	11.94	-12.39	5.02
	Min Load	5.04	3.34	12.13	12.06	12.14	12.07	-12.33	5.14
180V/50HZ	Full Load	4.91	3.26	12.04	11.84	11.99	11.91	-12.5	4.99
	Half Load	4.93	3.26	12.06	11.91	12.02	11.94	-12.4	5.03
	Min Load	5.04	3.34	12.14	12.06	12.14	12.07	-12.33	5.14
230V/50HZ	Full Load	4.91	3.24	12.02	11.83	12	11.9	-12.51	4.99
	Half Load	4.94	3.26	12.05	11.9	12.02	11.94	-12.4	5.02
	Min Load	5.04	3.34	12.14	12.06	12.14	12.07	-12.33	5.15
240V/50HZ	Full Load	4.91	3.24	12.04	11.83	12	11.9	-12.51	4.99
	Half Load	4.92	3.26	12.06	11.91	12.02	11.94	-12.4	5.02
	Min Load	5.04	3.34	12.14	12.06	12.14	12.07	-12.33	5.15
Reference Spec		+5/-5%	+5/-5%	+5/-5%	+5/-5%	+5/-5%	+5/-5%	+10/-10%	+5/-5%

3.OUTPUT RIPPLE & NOISE

3.1 Test Condition & Check

1.Test Condition:

(1.) Purpose: Measure the ripple & noise of output voltage under any condition.

(2.)Environmental Condition: Temperature: 25°C ;Relative Humidity: 65%

(3.) Test Conditions:

AC input voltage: The Maximum and minimum voltage of product specification

The output load is the maximum and minimum load of specification regulation.

Result limit: Ripple & Noise can not exceed the specified.

Output Load	Output Load Condition (A)							
	+5V	+3.3V	+12V1	+12V2	+12V3	+12V4	-12V	+5Vsb
Full Load	25	23.48	16	16	25	25	0.5	1.5

(Noise bandwidth is from 20MHZ. Add 0.1uf ceramic capacitor in parallel with a 10uf tantalum capacitor at output connector terminals for ripple & noise measurements.)

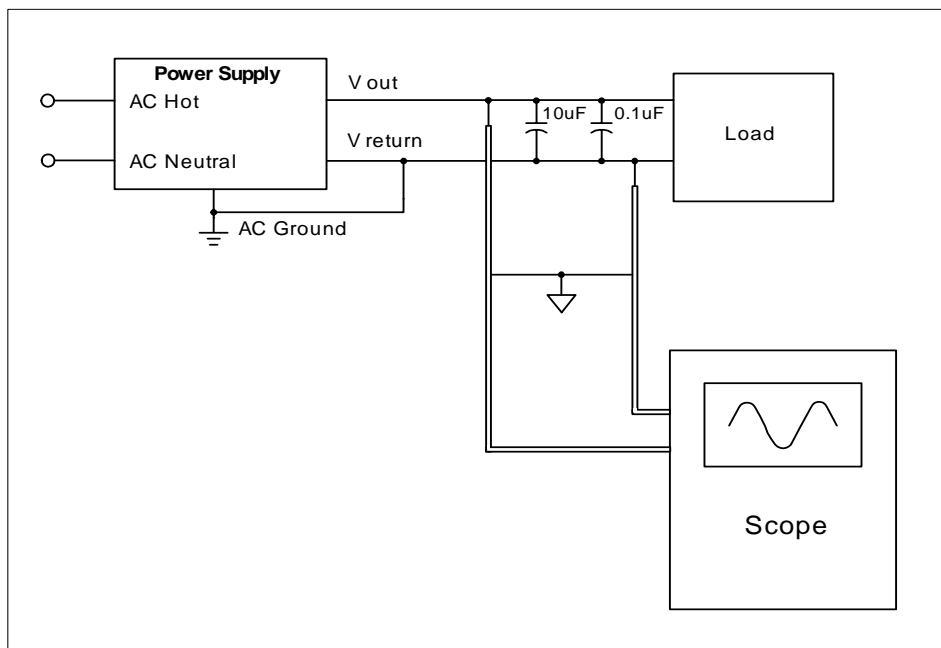

2.Check:

Measure the output ripple and peak to peak voltage ,

The ripple of power supply should be with in the specification

(Shown on the worst case of the each output and attached the waveform . As follows)

3.2 Test Result

Input Voltage (Vac)	Output	Output Load Condition (A)								R & N Vp-p (mv)
		+5V	+3.3V	+12V1	+12V2	+12V3	+12V4	-12V	5Vsb	
115Vac/60HZ	+5V	30	15.15	16	16	25	25	0.5	1.5	62.8
	+3.3V	20.2	30	16	16	25	25	0.5	1.5	54.4
	+12V1	25	23.48	20	12	25	25	0.5	1.5	112
	+12V2	25	23.48	12	20	25	25	0.5	1.5	86.4
	+12V3	25	23.48	10.5	10.5	36	25	0.5	1.5	107
	+12V4	25	23.48	10.5	10.5	25	36	0.5	1.5	116
	-12V	25	23.48	16	16	25	25	0.8	0.78	60.4
	5Vsb	24.22	23.48	16	16	25	25	0.2	3	37.6
230Vac/50HZ	+5V	30	15.15	16	16	25	25	0.5	1.5	61.6
	+3.3V	20.2	30	16	16	25	25	0.5	1.5	52
	+12V1	25	23.48	20	12	25	25	0.5	1.5	122
	+12V2	25	23.48	12	20	25	25	0.5	1.5	90
	+12V3	25	23.48	10.5	10.5	36	25	0.5	1.5	118
	+12V4	25	23.48	10.5	10.5	25	36	0.5	1.5	118
	-12V	25	23.48	16	16	25	25	0.8	0.78	123
	5Vsb	24.22	23.48	16	16	25	25	0.2	3	42.4

3.3 Measured Waveform

AC 115V/60HZ Full Load Condition Part 1

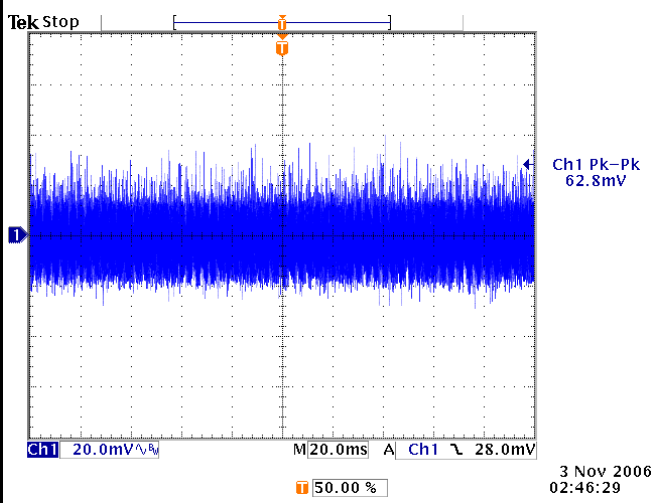

+5V Waveform

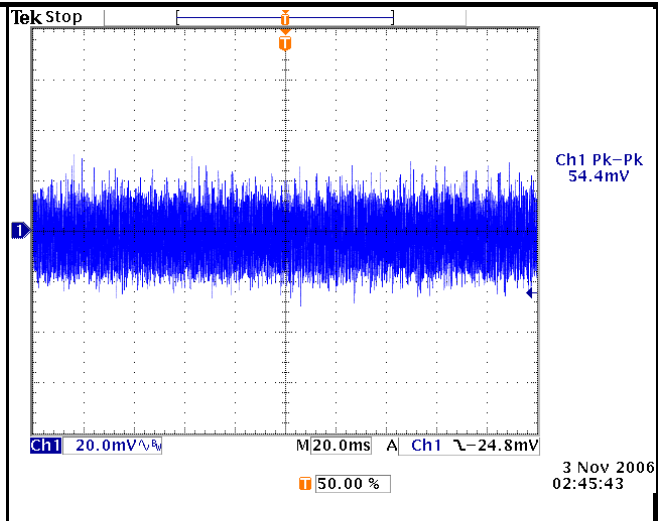

+3.3V Waveform

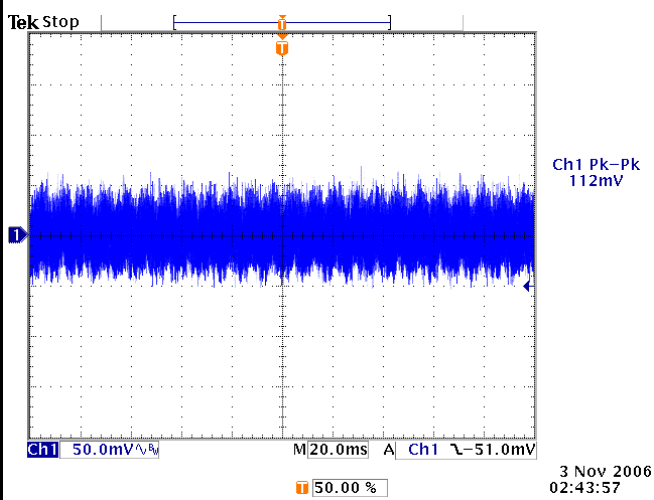

+12V1 Waveform

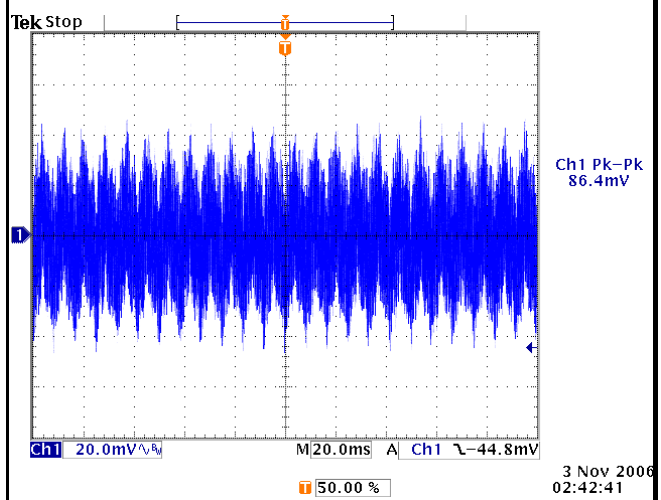

+12V2 Waveform

Ch1:Vo

AC 115V/60HZ Full Load Condition Part 2

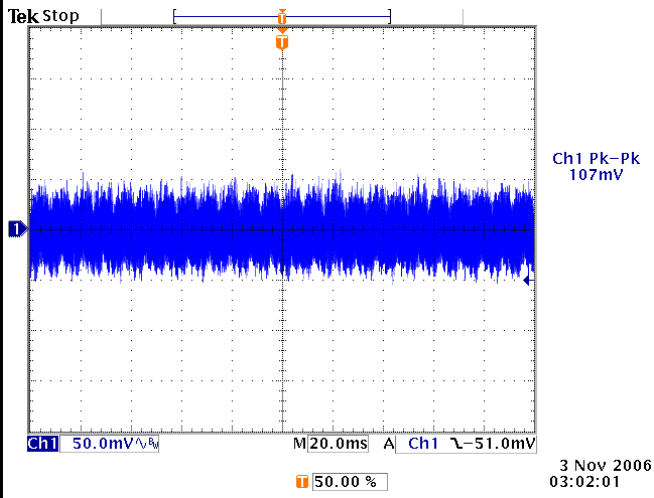

+12V3 Waveform

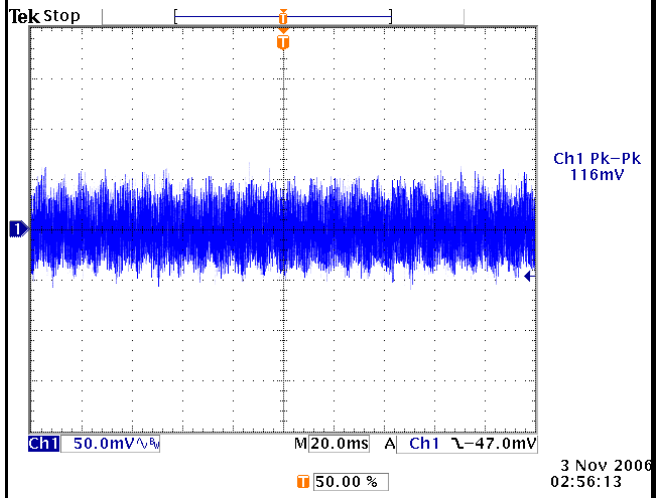

+12V4 Waveform

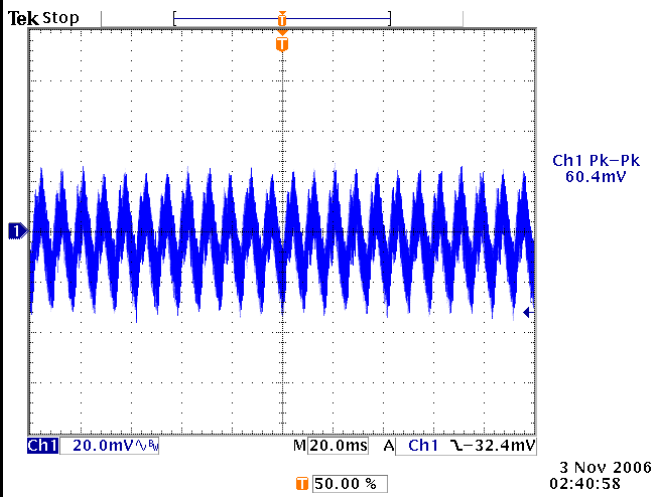

-12V Waveform

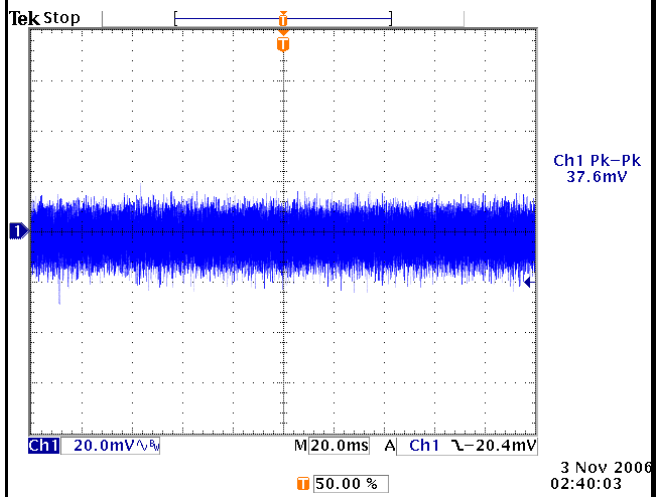

+5Vsb Waveform

Ch1:Vo

AC 230V/50HZ Full Load Condition Part 1

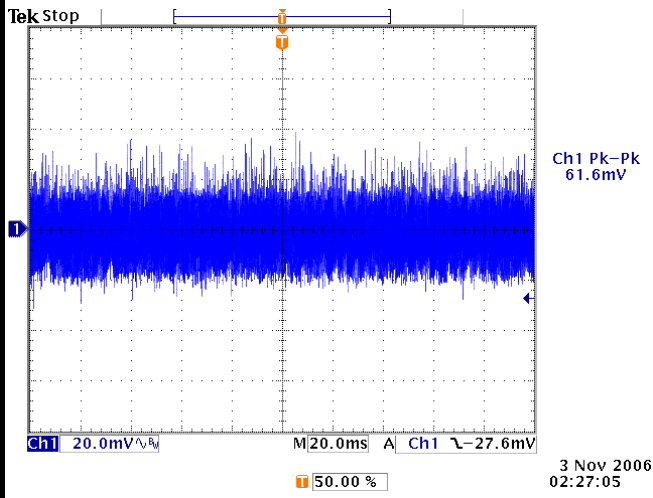

+5V Waveform

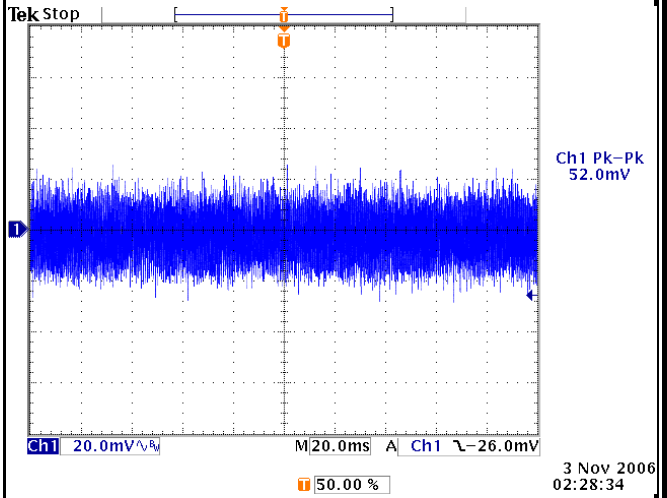

+3.3V Waveform

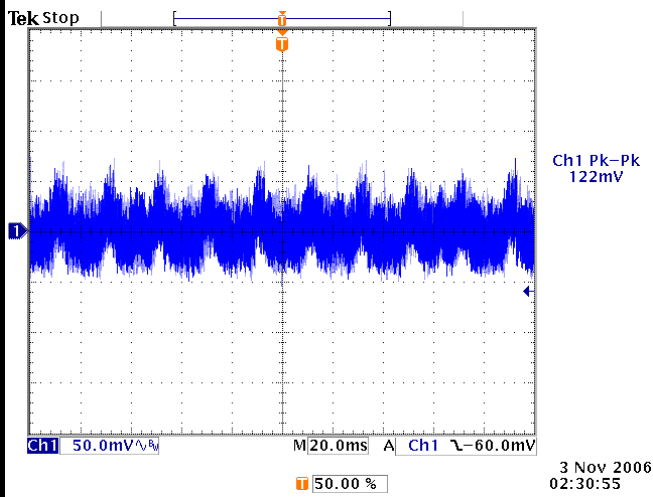

+12V1 Waveform

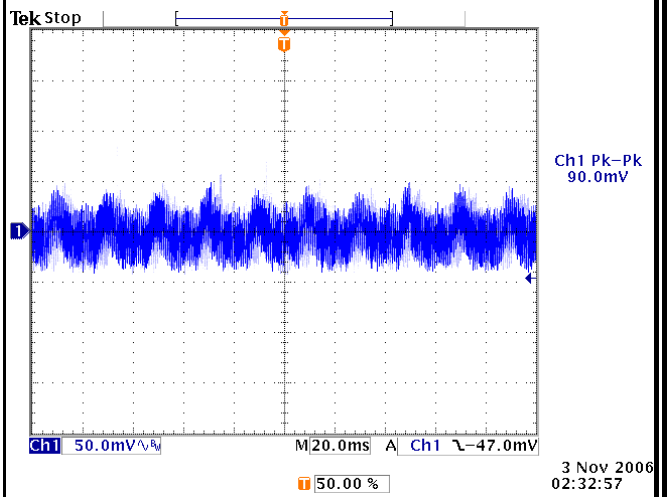

+12V2 Waveform

Ch1:Vo

AC 230V/50HZ Full Load Condition Part 2

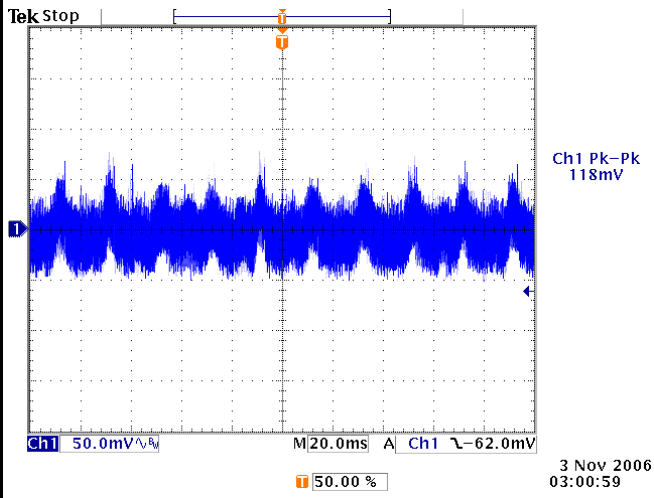

+12V3 Waveform

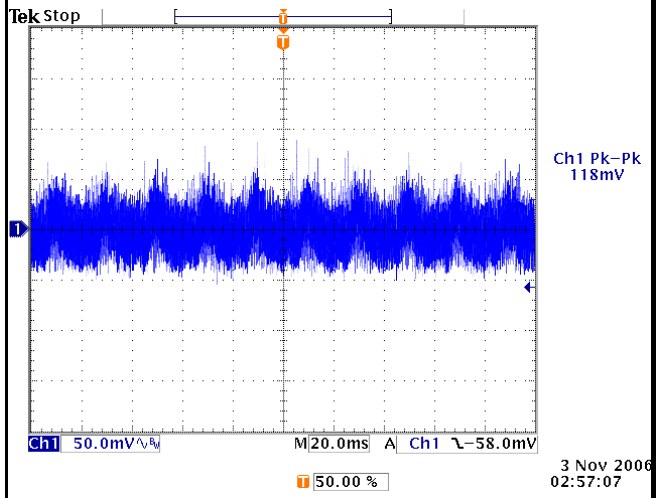

+12V4 Waveform

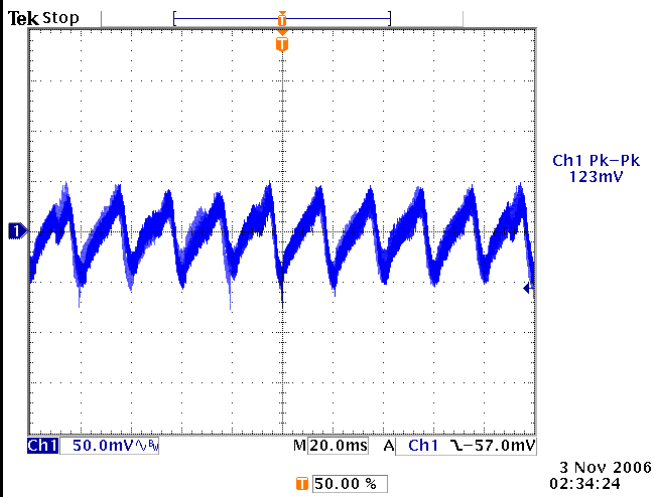

-12V Waveform

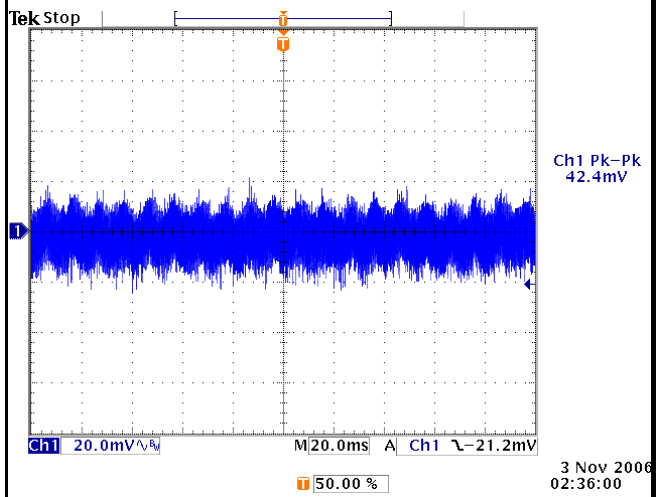

+5Vsb Waveform

Ch1:Vo

C. Power Cycle Test

1. AC ON/OFF CYCLING

1.1 Test Condition & Check

1. Test Condition:

Set the output loads at Full load and power On/Off by remote on/off at 100 times.

Power on 5 seconds and off 5 seconds for each condition

Output Load	Output Load Condition (A)							
	+5V	+3.3V	+12V1	+12V2	+12V3	+12V4	-12V	+5Vsb
Full Load	25	23.48	16	16	25	25	0.5	1.5

2. Check:

No any component damage and no any fault condition during the test

1.2 Test Result

Vin \ Vout	Measured Output Voltage Value							
	+5V(V)	+3.3V(V)	+12V1(V)	+12V2(V)	+12V3(V)	+12V4(V)	-12V(V)	+5Vsb(V)
115V/60HZ	4.89	3.24	12.02	11.82	11.98	11.89	-12.51	5.03
230V/50HZ	4.91	3.24	12.02	11.83	12	11.9	-12.51	4.99
Spec	+5/-5%	+5/-5%	+5/-5%	+5/-5%	+5/-5%	+5/-5%	+10/-10%	+5/-5%