

Intel LGA1366 Desktop

130W



P/N : CLP0533

Application for: Intel Bloomfield Processor



SPECIFICATION	
Compatibility	Intel Bloomfield Processor
Dimension	(L)95.0 x (W)77.3 x (H)97.8 mm
Fan Dimension	70 x 15 mm
Heat Sink Material	Aluminum Fin +Cooper Base +Heat pipe
Rated Voltage	12 V
Operating Range	10.8 ~ 13.2 V
Rated Current	0.06 ~ 0.45 A
Rated Speed	1000 ± 300 rpm ~ 6000 rpm ± 10 %
Air Flow	7.83 ~ 46.98 CFM
Static Pressure	0.25 ~ 8.94 mmH ₂ O
Noise Level	21 ~ 48 dBA
Speed Controlled Type	PWM
Connector	4 Pin
Bearing	One Ball Bearing
Life expectancy	40,000 Hrs
Weight	490 g
Thermal Interface Material	Dow Corning TC-5121
Thermal Resistance	0.288 °C/W



Top View



Copper Base



Aluminum Fins



Push Pin

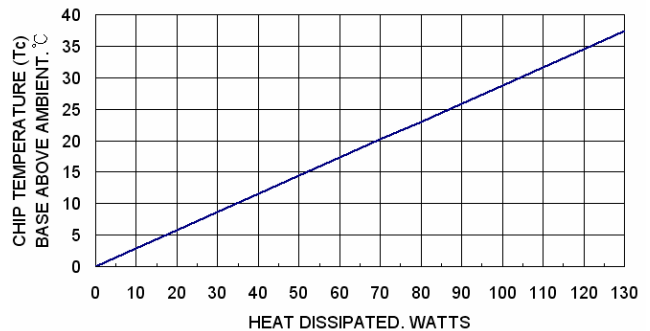

FEATURES:

- . Aluminum fin embedded with two heat pipes .
- . Heat pipe technology provides the best cooling performance .
- . Copper base.
- . PWM Speed controlled.
- . Push pin for easy installation.
- . Weight 490 g.
- . Side flow design for better system flow pattern.

DIMENSION

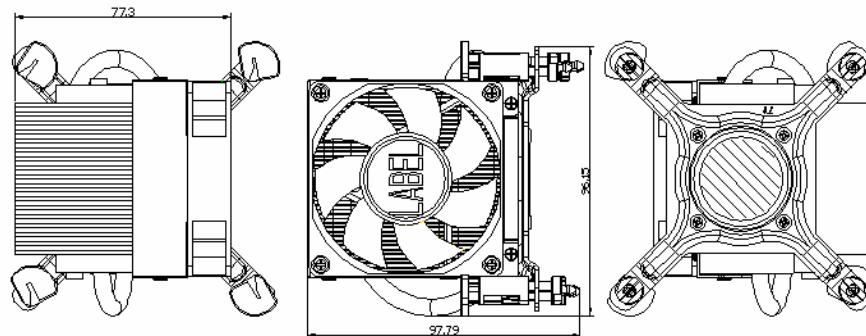

Unit: mm